

Heavy Duty ANSI Size Deadlatch

For Hollow Metal or Wood Doors

4920AN Series

ANSI/BHMA Type E8231 (Grade 1)

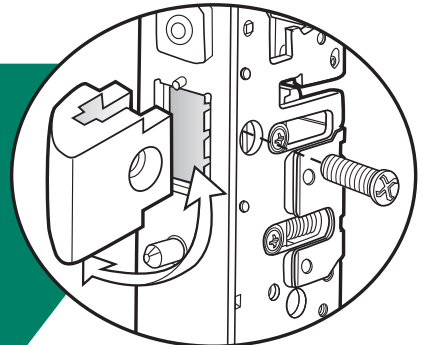
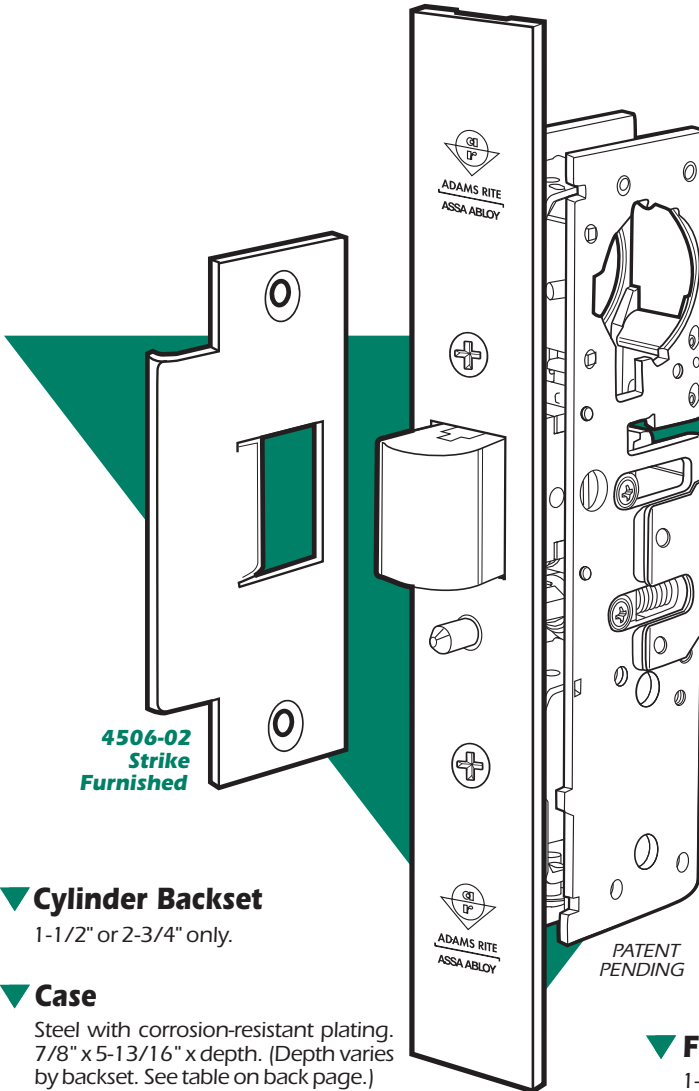

**Field Reversible
Latch Bolt**

▼ Cylinder Backset

1-1/2" or 2-3/4" only.

▼ Case

Steel with corrosion-resistant plating. 7/8" x 5-13/16" x depth. (Depth varies by backset. See table on back page.)

▼ Function

For hollow metal or wood doors prepared for hardware according to the specifications of the American National Standards Institute, the 4920AN Deadlatches provide precise traffic control. A key-controlled bolt hold-back feature allows a door to be free-swinging part of the day and exit-only when the bolt is free to latch. This allows a "locked" entrance to be used as an exit by customers or visitors already in the building. Interchangeable, without door modification, with any MS 1850SN Deadbolt of same faceplate shape and backset. Replaces 4520 and 4720 ANSI Deadlatches. 1-3/4" minimum door thickness required.

▼ Latch Bolt

5/8" x 1" x 5/8" throw. Solid brass. Handing is easily reversible using only a screwdriver.

▼ Auxiliary Latchpin

Stainless steel. Deadlocks latch bolt to prevent "loiding" or case-knife entry.

▼ Faceplate

1-1/4" x 8" Armored Flat Faceplate can also be adjusted in the field for right or left beveled edge doors.

▼ Strikes

Stainless steel, US32D Satin finish (630). 4506-02 Strike furnished to ANSI preparation specifications for flat jamb. (See also page SW-30 and Electric Strike section.)

▼ Operation

Turn key or operate handle to retract spring-loaded latch bolt. To hold bolt retracted, push it in and secure by reverse turn of key (see back page). Uses any standard mortise cylinder with MS® cam (see page SW-37).



4920AN Series Deadlatch

DIMENSIONS

INCHES
MILLIMETERS

Nominal, subject to tolerance extremes.

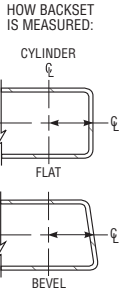
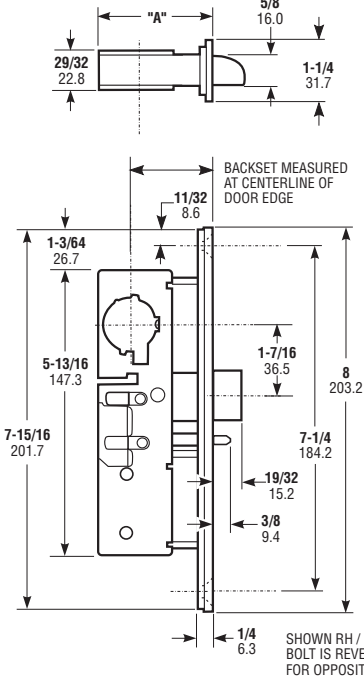

BACKSET	"A"
1-1/2" 38.1	2.14 54.3
2-3/4" 69.85	3.39 86.11

ARMORED FACEPLATE	
1-1/4" x 8"	
FLAT	24-0138-01-XXX

FACEPLATE CAN BE ADJUSTED FOR RIGHT OR LEFT BEVELED EDGE DOORS

SHOWN RH / LHR. BOLT IS REVERSIBLE FOR OPPOSITE HAND.

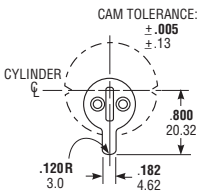

Cylinder Cam

4920AN Series Deadlatches are operable by any standard 1-5/32" diameter mortise cylinder with special MS® cam dimensioned as shown. Cylinders with MS® cams can be readily obtained from most cylinder manufacturers. See page SW-37 for cylinder make and trim ring information.

HOW TO ORDER

Specify quantity and the following information. Order related hardware separately.

Handing*
5 LH or RHR
6 RH or LHR

Strike
602 4506
000 Less Strike

*Handing can be reversed in field.

4920AN-46-602-313

Backsets
4 1-1/2"
5 2-3/4"

Faceplate Finishes
628 Clear Anodized
313 Dark Bronze Anod.
335 Black Anodized

INSTALLATION

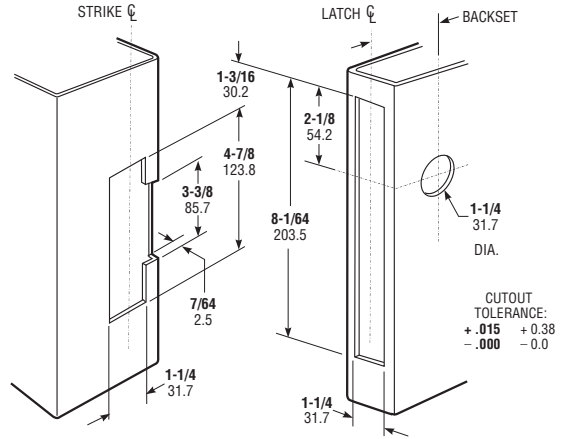

Jamb Preparation

Door Preparation

Identical to MS1850S Series (See also prep for 4591 Paddle)

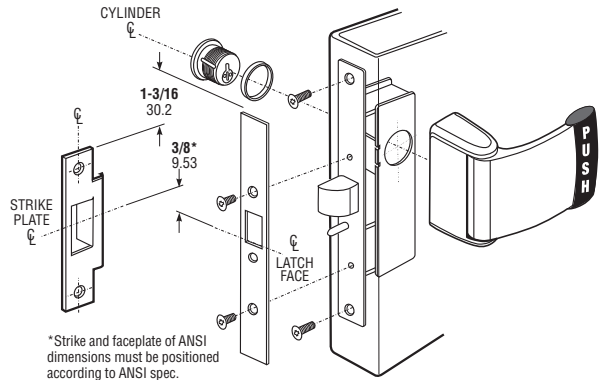

Latch, Paddle & Cylinder Installation

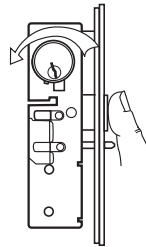

Bolt Holdback

A reverse turn of the key (while bolt is held fully retracted) retains the bolt, allowing the door to be free swinging.

OPTIONS

Backset, Strike and Finish must be specified when ordering. For Handles, see page SW-31, 32 & 33. For paddles, see page SW-34 and SW-35. For 4593 outside entry Latch Pull, see page SW-36.

STANDARD PACKAGE

Individually boxed with faceplate, strike and machine screws for mounting. Order cylinders, paddle, handle or latch pull separately. Shipping weight: 1-1/4 lbs.